



**CORE VAC
PARTS LIST**

**CVG1
GAS VAC**

August, 2021

Part #: 1802732-02

Table of Contents

Contents

Frame	4
Filter Tank	5
Filter Cleaner	6
Filter Cleaner Base	7
Chain Cover	8
Chain Tensioner	9
Rotation Plate Guard	10
Filter Plate	11
Filter Shaft	12
Rotation Plate	13
Motor and Gearbox	14
Shake Bar	15
Pulley Assembly	16
Impeller Housing	17
Impeller	18
Dust Drum	19
Hose Inlet	20
Engine	21

CVG1 PARTS LIST

Frame

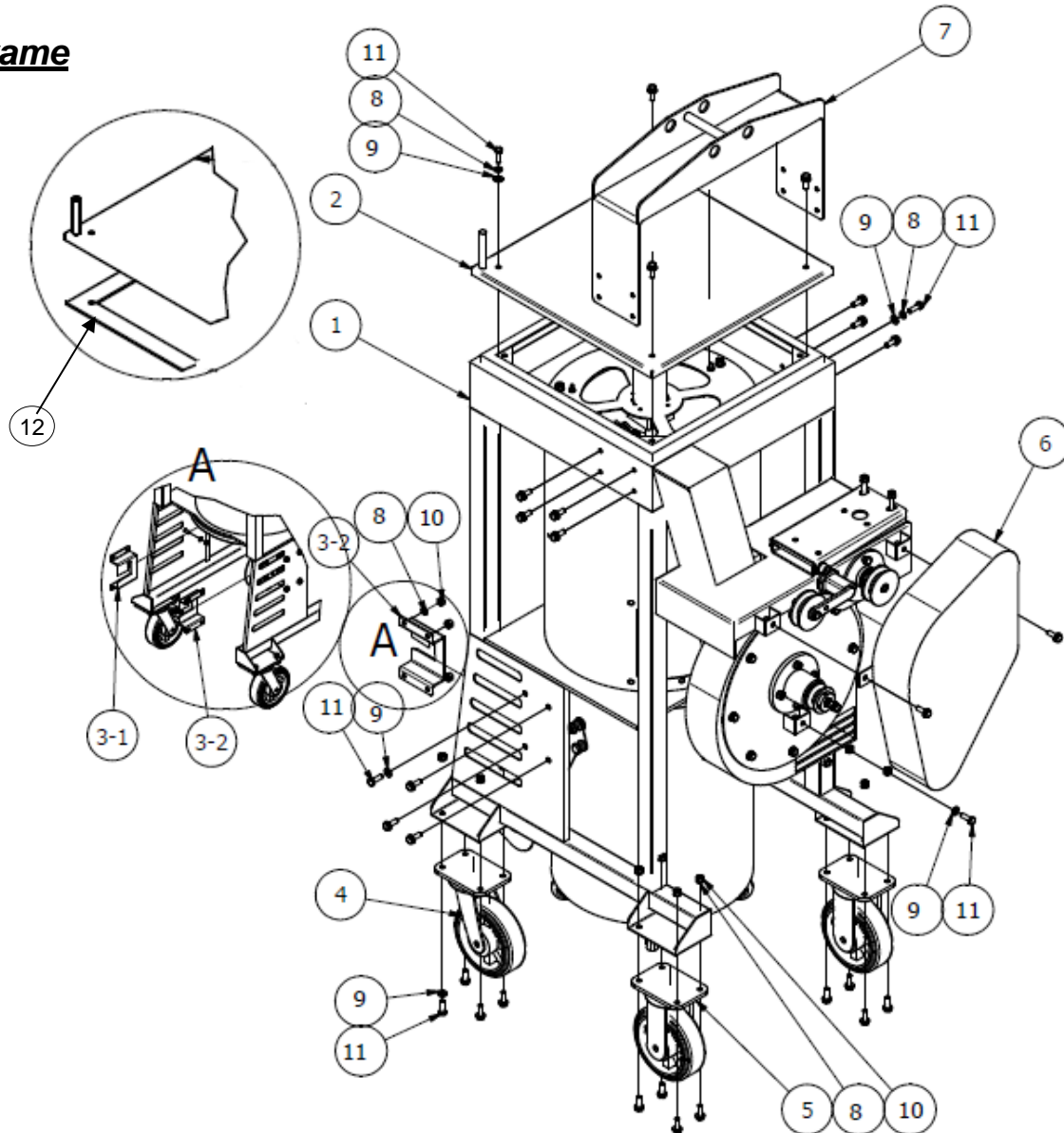

FIG	DP #	QTY	DESCRIPTION
1	2508931	1	MAIN FRAME
2	2508837	1	UPPER TANK LID
3-1	2508832	1	LEVER SUPPORT STAND LEFT
3-2	2508833	1	LEVER SUPPORT STAND RIGHT
4	2508834	2	SWIVEL WHEEL 6"
5	2508835	2	WHEEL 6"
6	2508849	1	BELT COVER
7	2508847	1	UPPER LIFTING STAND
8	2508884	37	M10 SPRING WASHER
9	2508885	64	M10 WASHER
10	2508886	27	M10 NUT
11	2508887	39	M10X30 BOLT
12	2508689	1	LID SEAL

CVG1 PARTS LIST

Filter Tank

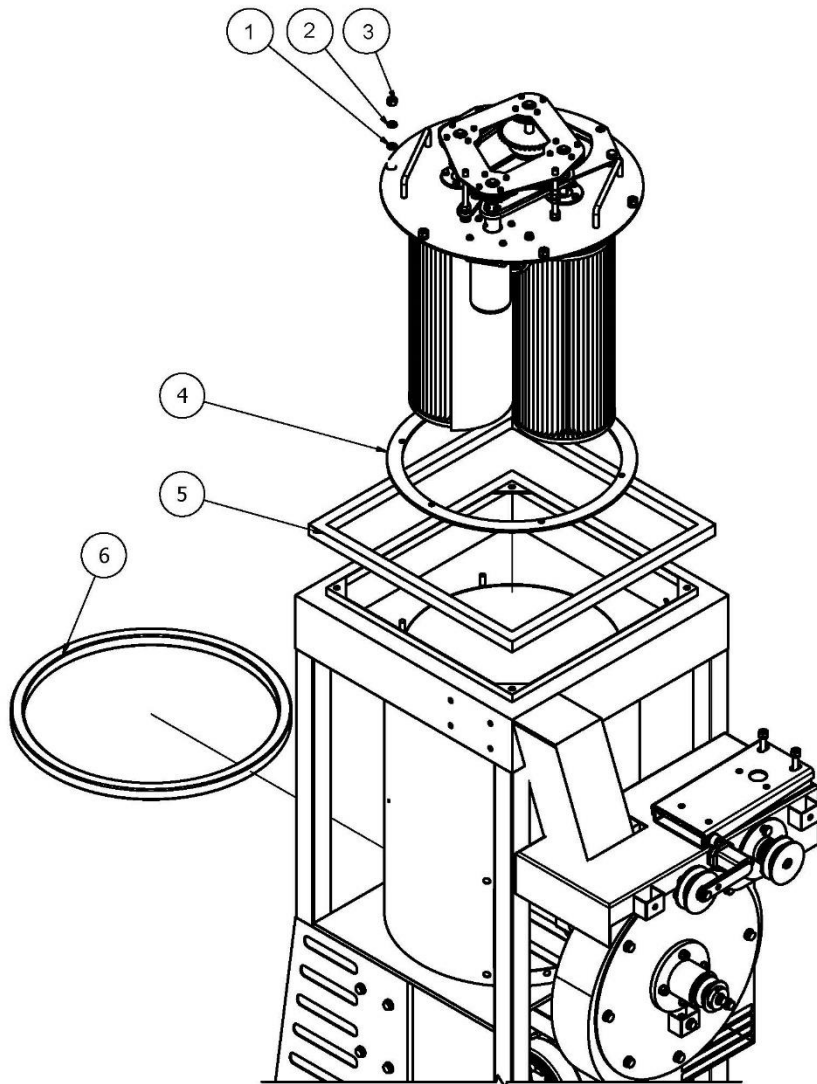
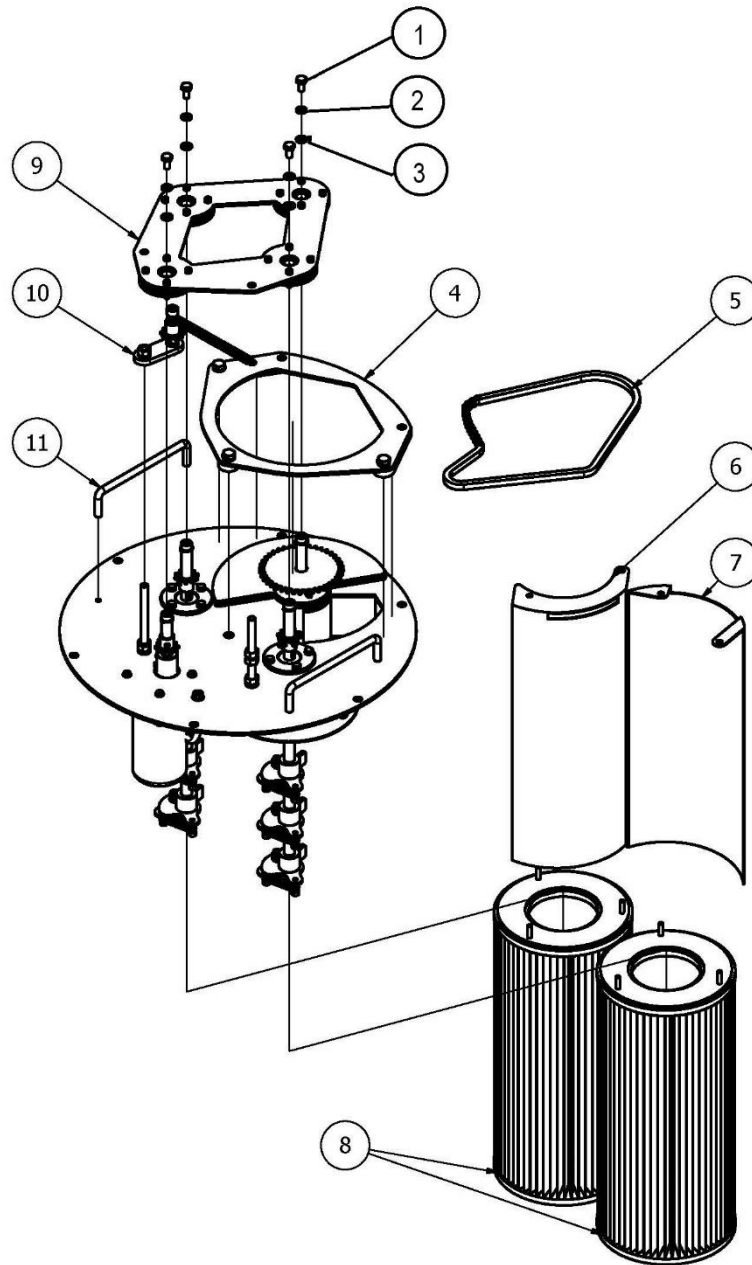

FIG	DP #	QTY	DESCRIPTION
1	2508885	6	M10 WASHER
2	2508884	6	M10 SPRING WASHER
3	2508886	6	M10 NUT
4	2508853	1	FILTER PLATE SEAL
5	2508843	1	UPPER COVER SEAL
6	2508844	1	DUST DRUM SEAL

CVG1 PARTS LIST

Filter Cleaner



	DP #	QTY	DESCRIPTION
1	2508747	4	M8X16 BOLT
2	2509155	4	M8 SPRING WASHER
3	2508891	4	M8 WASHER
4	2508715	1	ROTATION RAIL PLATE COVER SET
5	2508949	1	CHAIN
6	2508720	1	FILTER COVER RIGHT
7	2508721	1	FILTER COVER LEFT
8	2508947	2	TWIN MAIN FILTER
9	2508705	4	CHAIN COVER SET
10	2508710	1	CHAIN TENSION SET
11	2508714	1	FILTER HANDLE

CVG1 PARTS LIST

Filter Cleaner Base

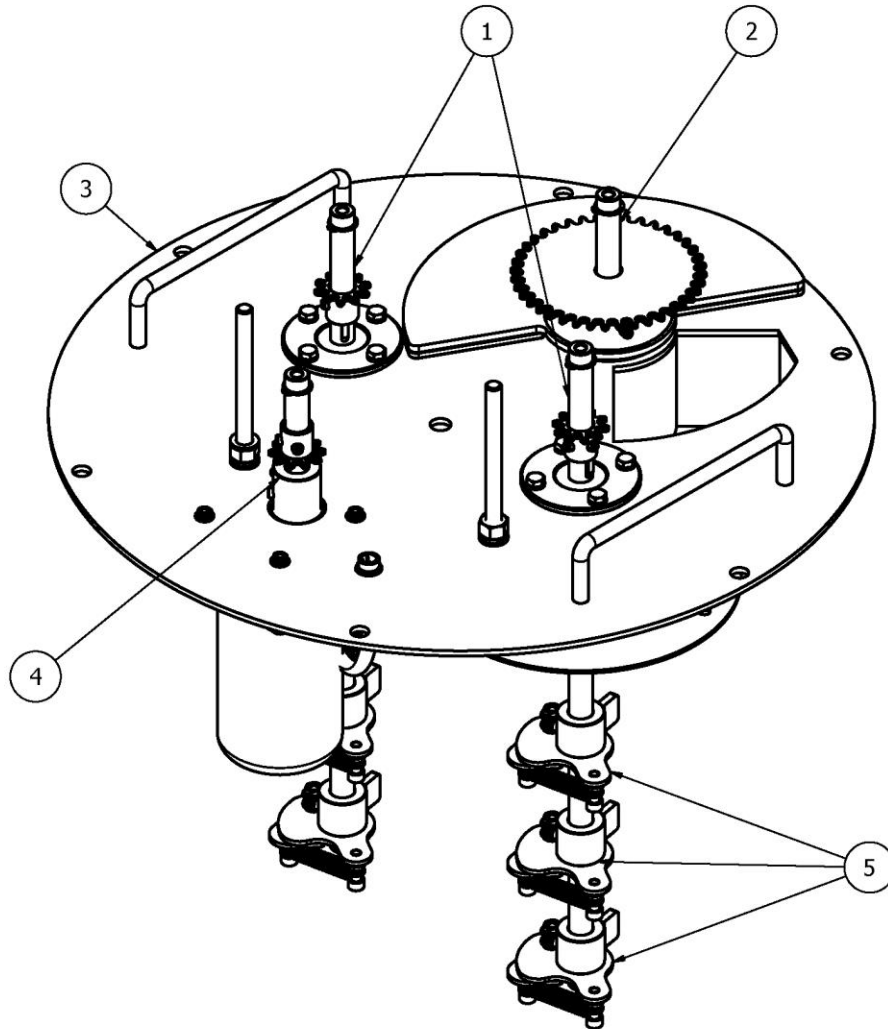

FIG	DP #	QTY	DESCRIPTION
1	2508726	2	FILTER SHAKE BAR SHAFT SET
2	2508734	1	ROTATION PLATE SET
3	2508723	1	FILTER PLATE SET
4	2508741	1	REDUCER MOTOR PART
5	2508743	2	SHAKE BAR SET

CVG1 PARTS LIST

Chain Cover

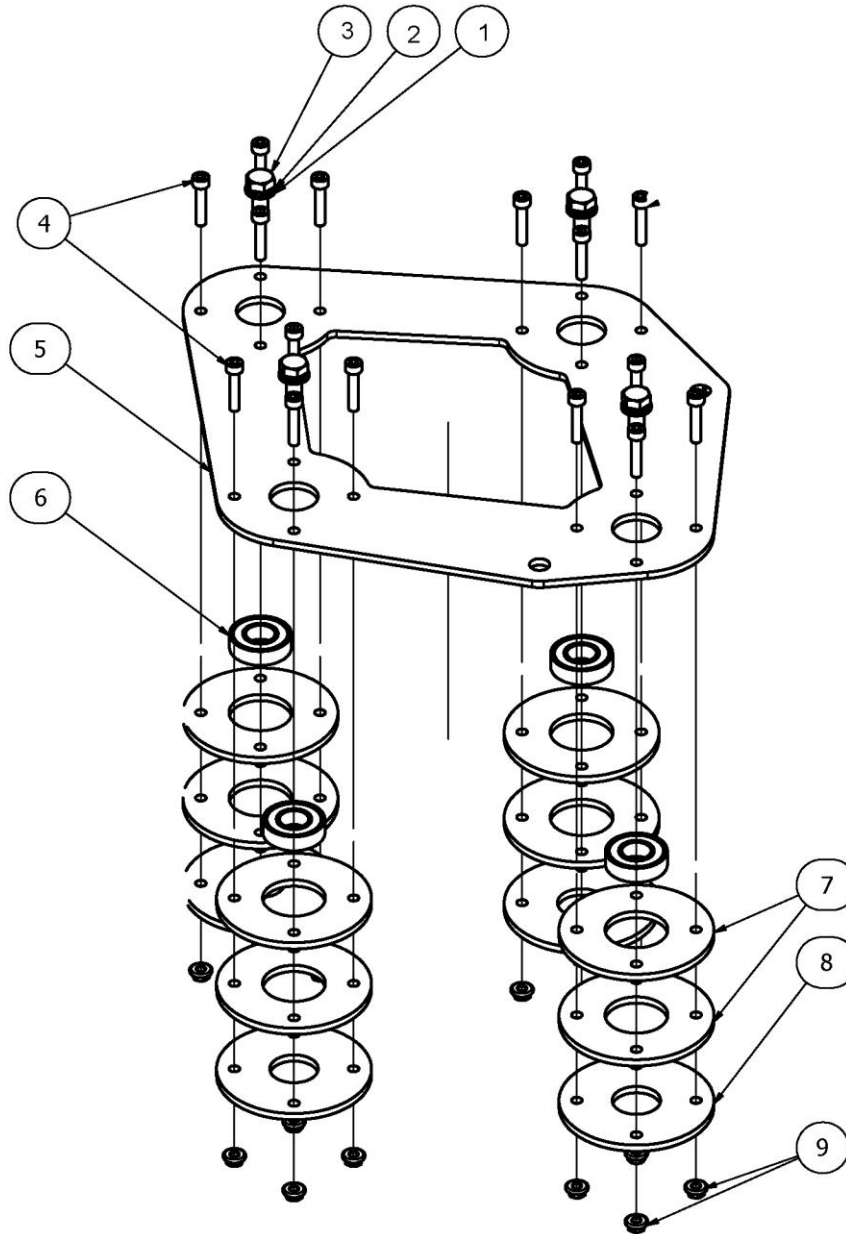

FIG	DP #	QTY	DESCRIPTION
1	2508891	4	M8 WASHER
2	2509155	4	M8 SPRING WASHER
3	2508747	4	M8X16 BOLT
4	2508748	16	M5X25 HEX BOLT
5	2508706	1	CHAIN COVER PLATE
6	2508707	4	SUPPORT BEARING
7	2508708	4	COVER BEARING HOUSING 1
8	2508709	8	COVER BEARING HOUSING 2
9	2508894	16	M5 FLANGE NUT

CVG1 PARTS LIST

Chain Tensioner

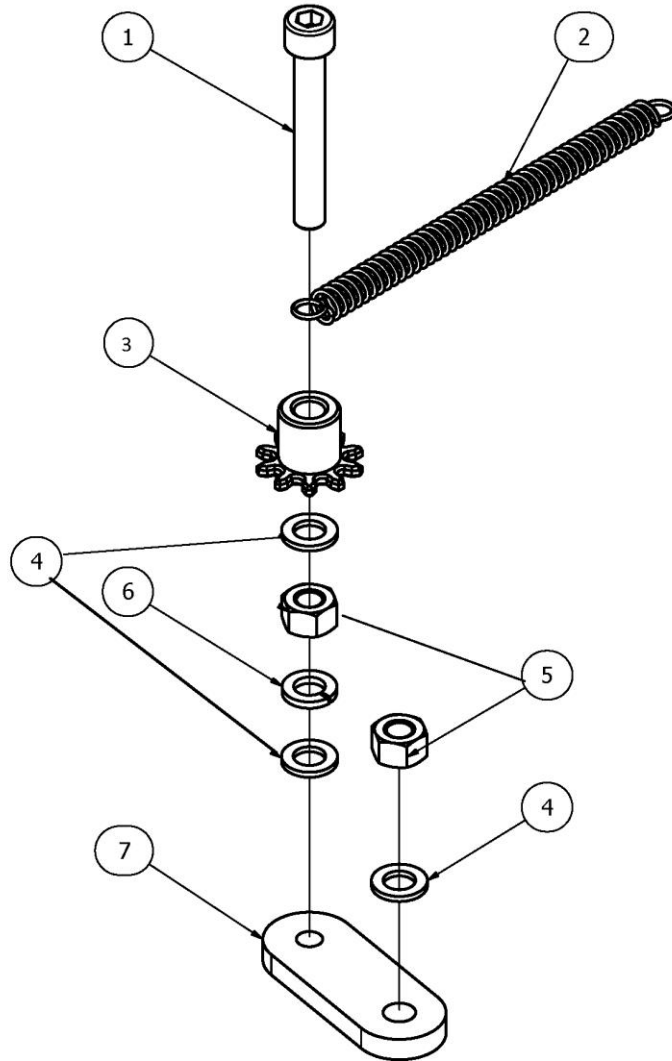

FIG	DP #	QTY	DESCRIPTION
1	2508750	1	M10X70 HEX BOLT
2	2508712	1	CHAIN TENSION SPRING
3	2507813	1	CHAIN TENSION GEAR
4	2508885	3	M10 WASHER
5	2508886	2	M10 NUT
6	2508884	1	M10 SPRING WASHER
7	2508711	1	CHAIN TENSION PLATE

CVG1 PARTS LIST

Rotation Plate Guard

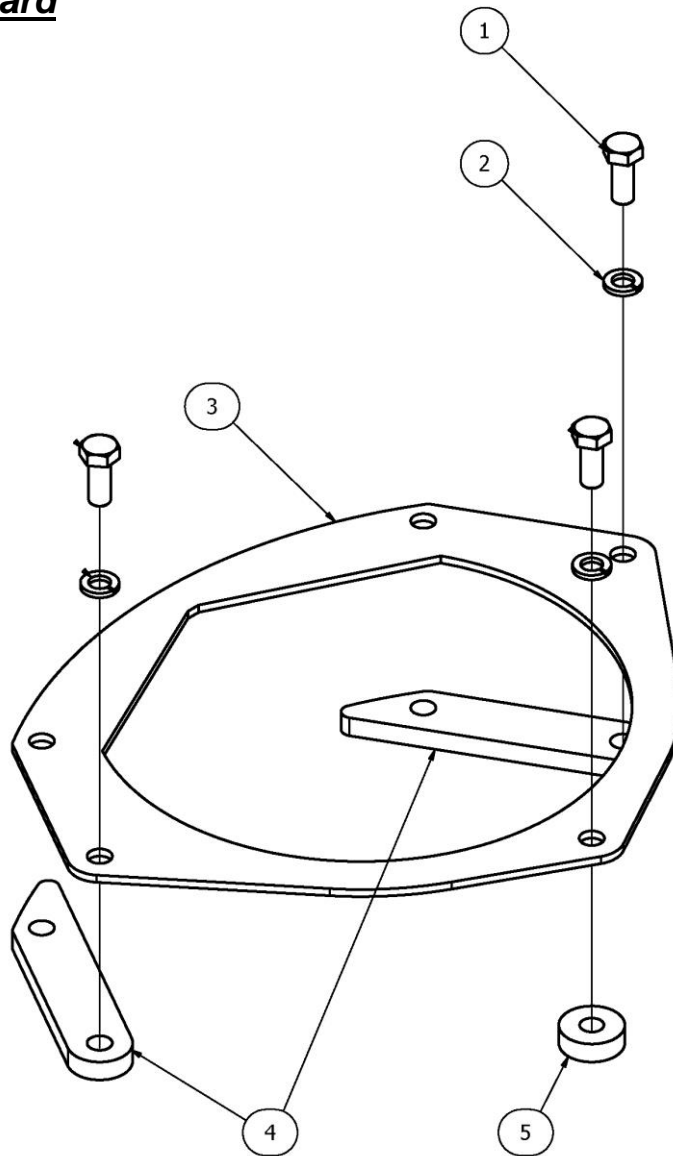

FIG	DP #	QTY	DESCRIPTION
1	2508749	3	M10X25 BOLT
2	2508884	3	M10 SPRING WASHER
3	2508716	1	ROTATION RAIL PLATE COVER
4	2508717	2	ROTATION PLATE RAIL SPACER 1
5	2508718	1	ROTATION PLATE RAIL SPACER 2

CVG1 PARTS LIST

Filter Plate

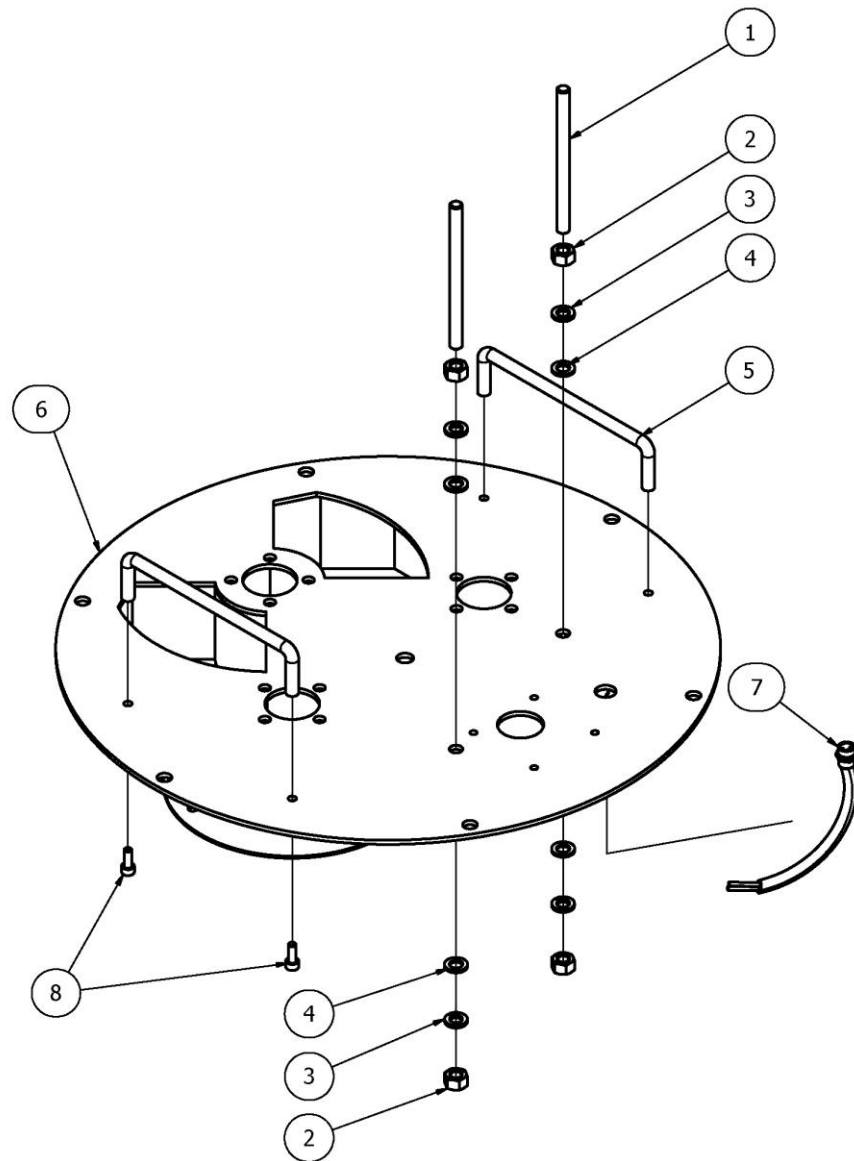

FIG	DP #	QTY	DESCRIPTION
1	2508751	2	M10X135 FULL THREADED BOLT
2	2508886	4	M10 NUT
3	2508884	4	M10 SPRING WASHER
4	2508885	4	M10 WASHER
5	2508714	2	FILTER HANDLE
6	2508724	1	FILTER PLATE
7	2508725	1	TERMINAL SET
8	2508752	4	M6X16 SOC SCREW

CVG1 PARTS LIST

Filter Shaft

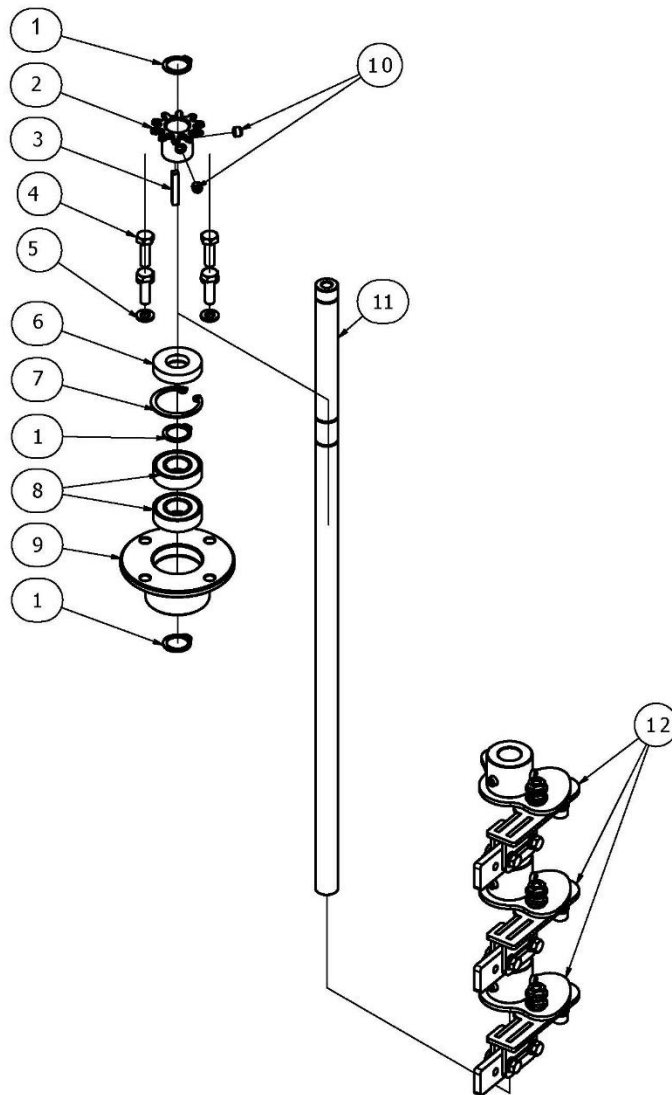

FIG	DP #	QTY	DESCRIPTION
1	2508727	3	RETAINING RING 15 (C TYPE OUTSIDE)
2	2508728	1	CHAIN GEAR 35B 12
3	2508729	1	KEY 4 X 4
4	2508758	4	M6X20 BOLT
5	2508889	4	M6 WASHER
6	2508730	6	15X32X7 RETAINER SEAL
7	2508731	1	RETAINING RING 32 (C TYPE INSIDE)
8	2508707	2	SUPPORT BEARING
9	2508732	1	GEAR BEARING HOUSING
10	2508753	2	M6X8 SET SCREW
11	2508733	1	SHAKE BAR SHAFT(LONG)
12	2508743	1	SHAKE BAR SET

CVG1 PARTS LIST

Rotation Plate

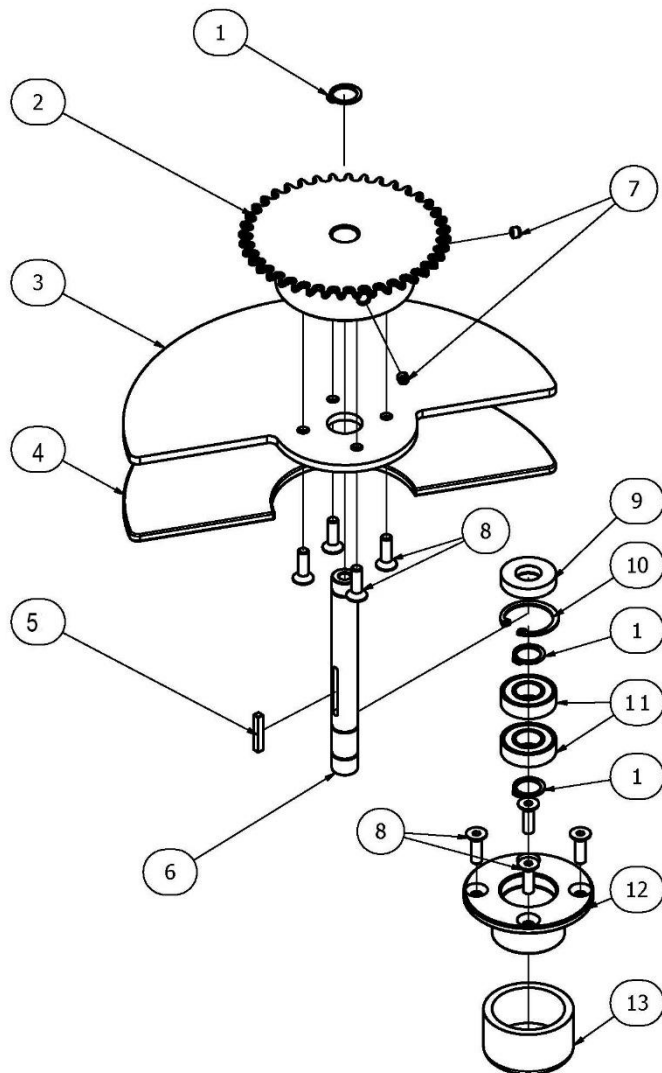

FIG	DP #	QTY	DESCRIPTION
1	2508727	3	RETAINING RING 15 (C TYPE OUTSIDE)
2	2508735	1	GEAR 35B 40
3	2508736	1	ROTATION PLATE
4	2508737	1	ROTATION PLATE RUBBER
5	2508729	1	KEY 4 X 4
6	2508738	1	SHAFT(SHORT)
7	2508753	2	M6X8 SET SCREW
8	2508754	8	M6X20 FLAT HEAD SOC SCREW
9	2508730	1	15X32X7 RETAINER SEAL
10	2508731	1	RETAINING RING 32 (C TYPE INSIDE)
11	2508707	2	SUPPORT BEARING
12	2508740	1	ROTATION PLATE BEARING HOUSING
13	2508739	1	RUBBER CAP

CVG1 PARTS LIST

Motor and Gearbox

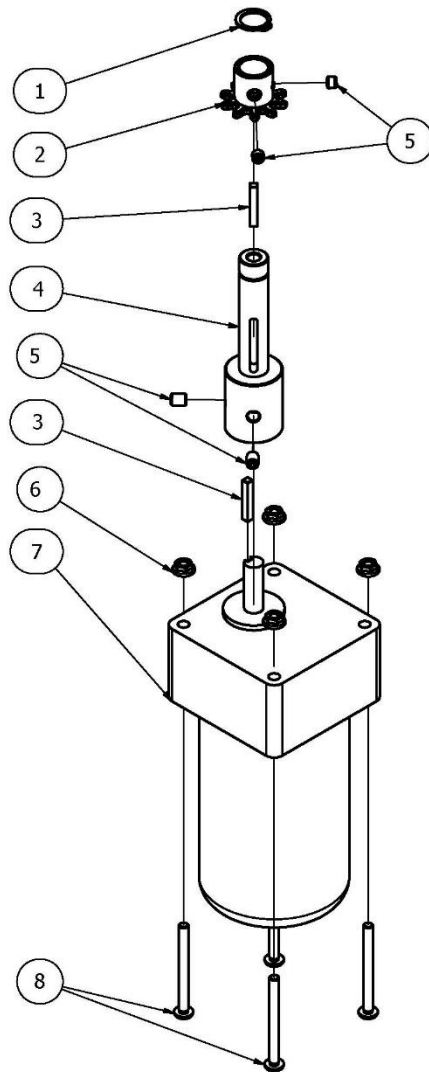

FIG	DP #	QTY	DESCRIPTION
1	2508727	1	RETAINING RING 15 (C TYPE OUTSIDE)
2	2508728	1	CHAIN GEAR 35B 12
3	2508729	2	KEY 4 X 4
4	2508742	1	SHAFT (MOTOR AXIS)
5	2508753	4	M6X8 SET SCREW
6	2508755	4	M5 MOTOR NUT
7	2508838	1	REDUCER MOTOR SET
8	2508756	4	M5X55 MOTOR BOLT

CVG1 PARTS LIST

Shake Bar

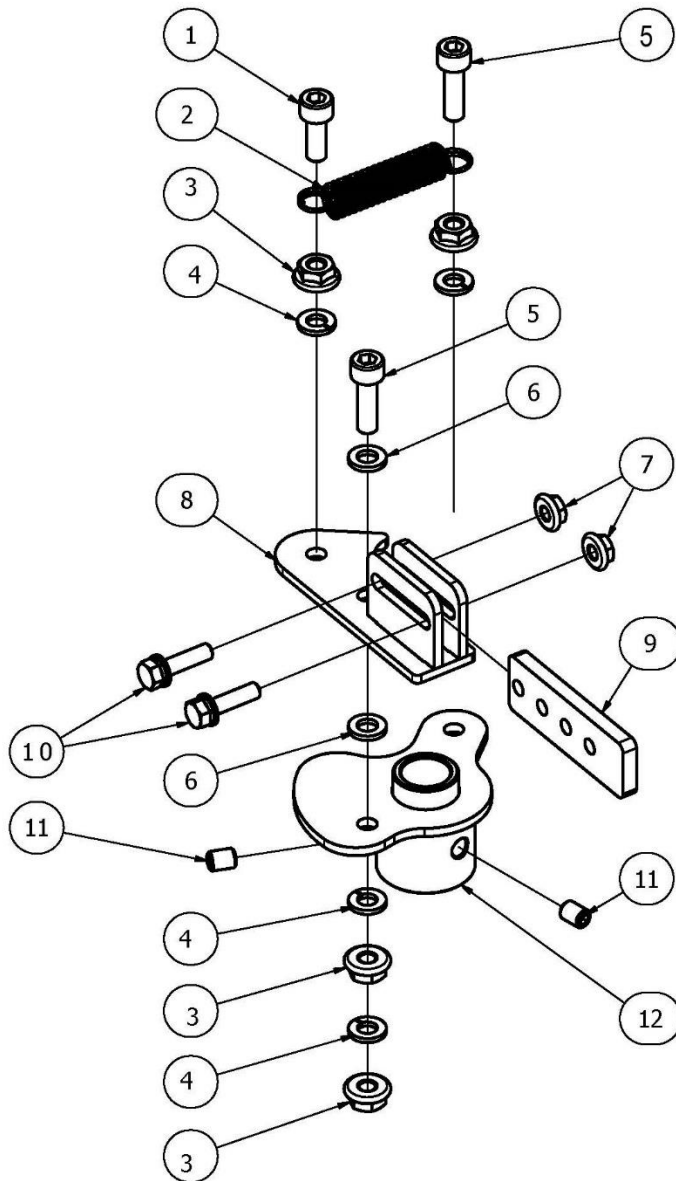

FIG	DP #	QTY	DESCRIPTION
1	2508890	1	M6X15 SOC SCREW
2	2508584	1	SPRING
3	2508888	4	M6 NUT
4	2509147	4	M6 SPRING WASHER
5	2508757	2	M6X20 SOC SCREW
6	2508889	2	M6 WASHER
7	2508894	2	M5 FLANGE NUT
8	2508744	1	SHAKE BAR BRACKET
9	2508746	1	FLAT BLUE CHIP
10	2508895	2	M5 BOLT SET
11	2508753	2	M6X8 SET SCREW
12	2508745	1	SHAKE BAR COLLAR

Pulley Assembly

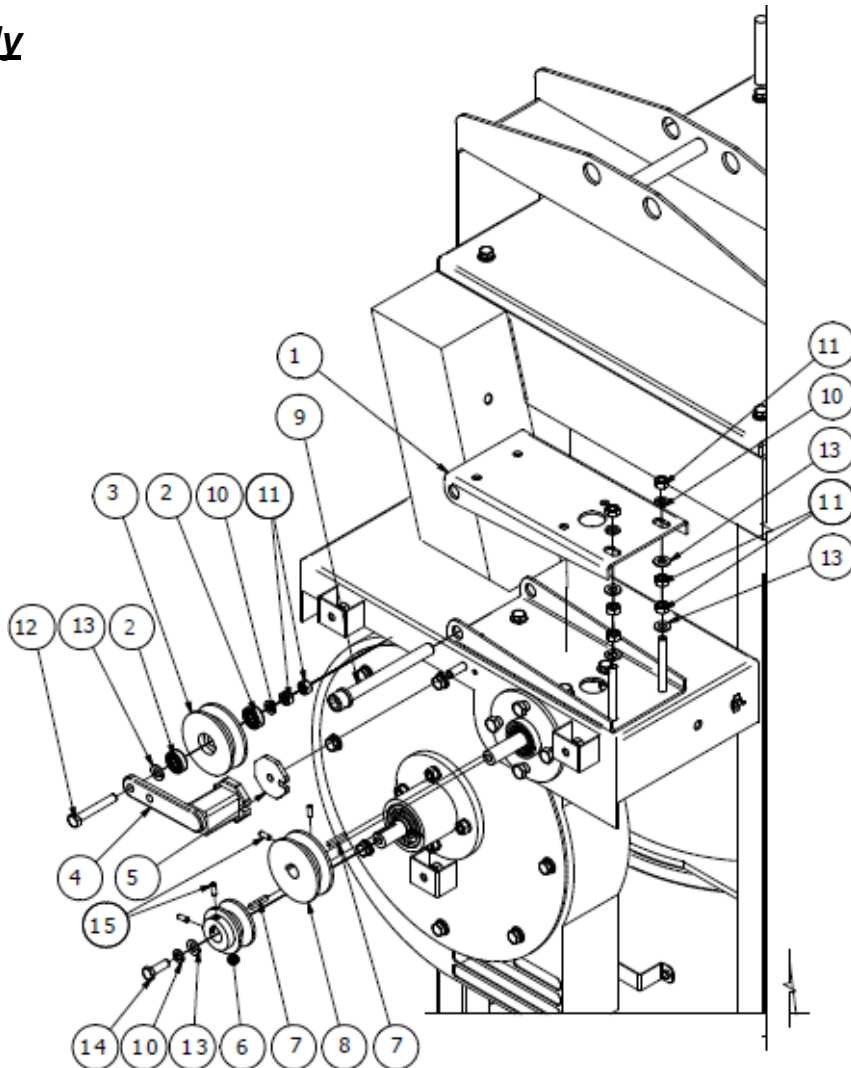

FIG	DP #	QTY	DESCRIPTION
1	2508857	1	ENGINE STAND UPPER PART
2	2508850	2	NSK 6200 BEARING
3	2508846	1	TENSIONER PULLEY
4	2508848	1	PULLEY TENSIONER
5	2508854	1	TENSIONER WASHER
6	2508868	1	IMPELLER PULLEY
7	2508852	2	KEY 5 x 5
8	2508851	1	SUPPORT PULLEY
9	2508899	1	M16X170 SOC SCREW
10	2508884	4	M10 SPRING WASHER
11	2508886	8	M10 NUT
12	2508898	1	M10X70 BOLT
13	2508885	6	M10 WASHER
14	2508887	1	M10X30 BOLT
15	2508897	4	M6X16 SET SCREW

CVG1 PARTS LIST

Impeller Housing

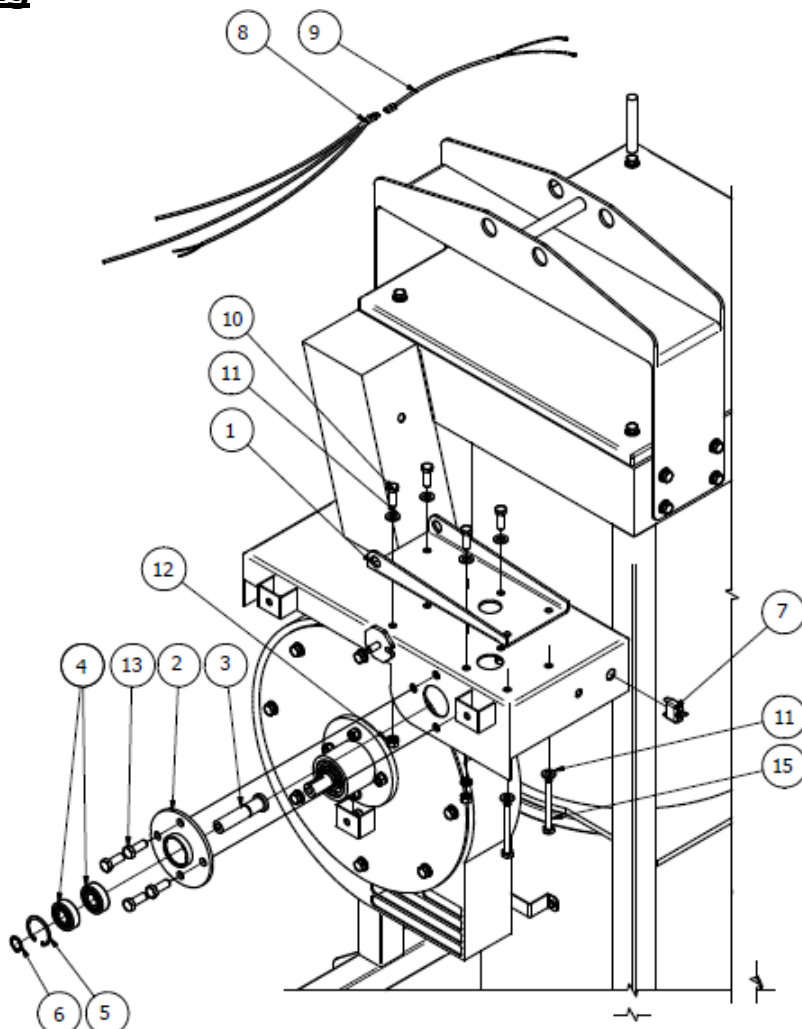

FIG	DP #	QTY	DESCRIPTION
1	2508858	1	ENGINE STAND BELOW PART
2	2508862	1	ASSISTING PULLEY BEARING HOUSING
3	2508860	1	ASSISTING PULLEY SHAFT
4	2508861	2	BEARING
5	2508855	1	47X1.8 SNAP RING(INSIDE)
6	2508856	1	20X1.2 SNAP RING(OUTSIDE)
7	2508585	1	ON/ OFF SWITCH
8	2508859	1	ENGINE & MOTOR WIRE
9	2508867	1	BATTERY WIRE
10	2508887	4	M10X30 BOLT
11	2508885	4	M10 WASHER
12	2508886	4	M10 NUT
13	2508936	2	M12X30 BOLT SET

CVG1 PARTS LIST

Impeller

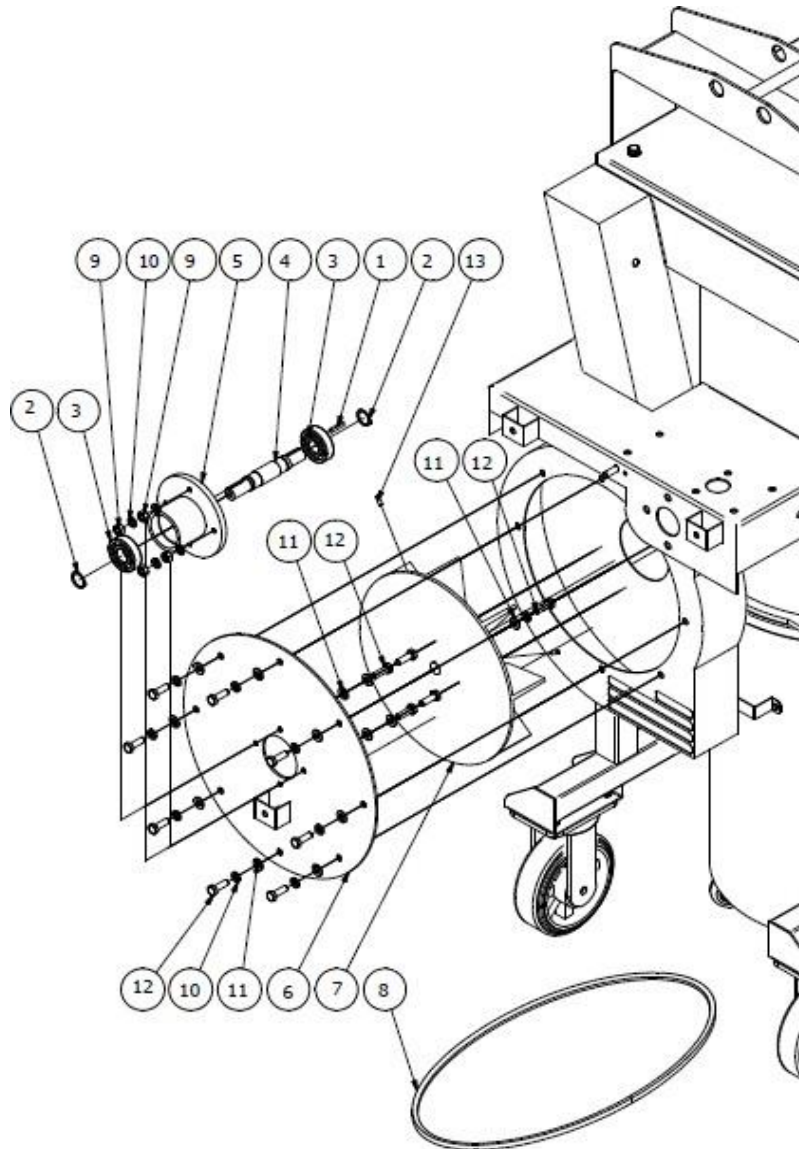

FIG	DP #	QTY	DESCRIPTION
1	2508852	2	KEY 5 x 5
2	2508876	2	25X1.2 SNAP RING(OUTSIDE)
3	2508869	2	NSK 6305 BEARING
4	2508865	1	IMPELLER SHAFT
5	2508866	2	IMPELLER BEARING HOUSING
6	2508864	1	IMPELLER COVER
7	2508863	2	IMPELLER BLOWER WHEEL
8	2508870	1	BELT B-48
9	2508886	4	M10 NUT
10	2508884	12	M10 SPRING WASHER
11	2508885	16	M10 WASHER
12	2508887	12	M10X30 BOLT
13	2508897	1	M6X16 SET SCREW

CVG1 PARTS LIST

Dust Drum

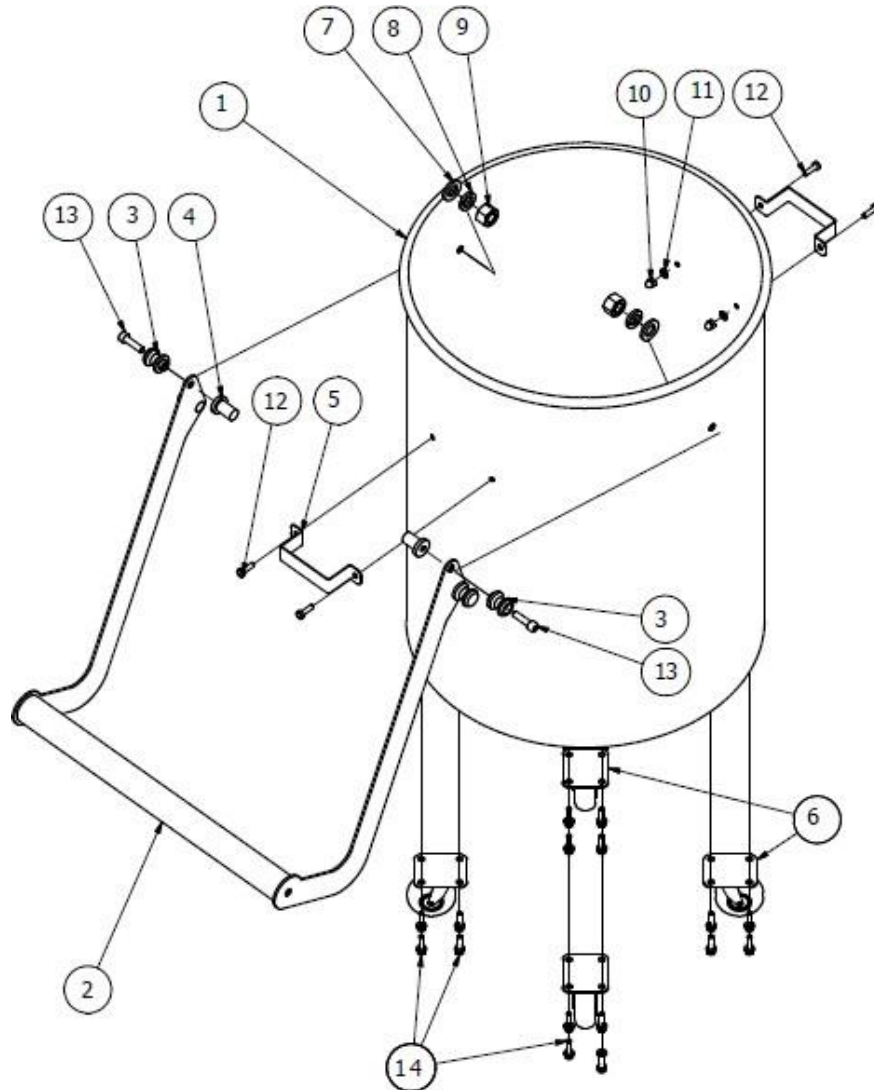

FIG	DP #	QTY	DESCRIPTION
1	2508874	1	DUST DRUM
2	2508871	1	DUST DRUM LEVER
3	2508873	2	LEVER PARTS
4	2508872	2	LEVER BUSHING
5	2508877	2	DUST DRUM HANDLE
6	2508875	4	DUST DRUM WHEEL 2.5"
7	2508939	2	M16 WASHER
8	2508938	2	M16 SPRING WASHER
9	2508937	2	M16 NUT
10	2508941	4	M6 CAP NUT
11	2508889	4	M6 WASHER
12	2508940	4	M6X20 BOLT SET
13	2508943	2	M8X35 SOC SCREW
14	2508942	16	M6X25 FLANGE NUT

CVG1 PARTS LIST

Hose Inlet

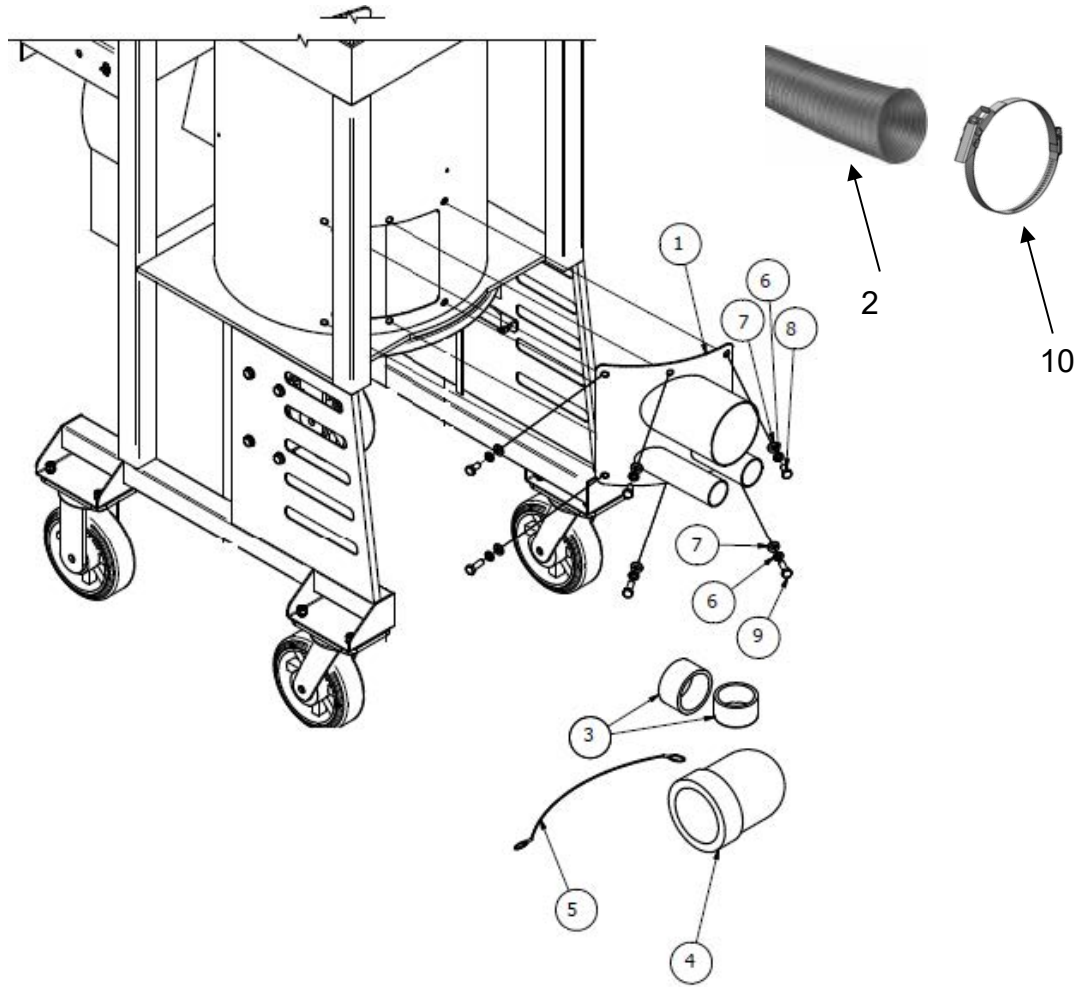

FIG	DP #	QTY	DESCRIPTION
1	2508878	1	HOSE INLET
2	2505835	1	5"x15' HOSE
3	2509169	2	INLET COVER(SMALL)
4	2508881	1	INLET COVER(LARGE)
5	2508882	1	INLET WIRE
6	2508884	6	M10 SPRING WASHER
7	2508885	6	M10 WASHER
8	2508883	3	M10x20 BOLT
9	2508887	3	M10X30 BOLT
10	2505870	2	5" HOSE CLAMP

CVG1 PARTS LIST

Engine

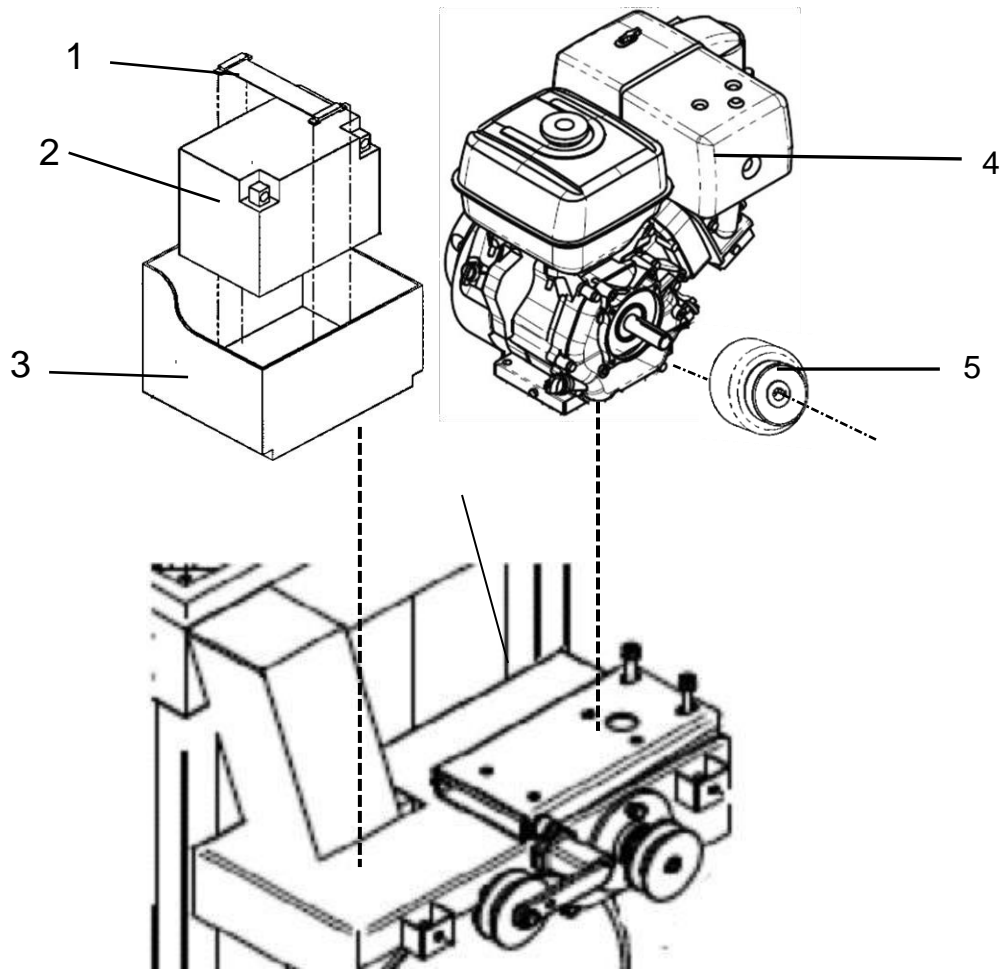

FIG	DP #	QTY	DESCRIPTION
1	2508934	1	BATTERY STRAP
2	2802378	1	BATTERY
3	2508946	1	BATTERY BOX
	4244139	1	BOX RUBBER
4	2601110	1	ENGINE
5	2505868	1	CLUTCH
6	2801029	1	FUSE HOLDER

EQUIPMENT AND PARTS WARRANTY

Diamond Products warrants all equipment manufactured by it against defects in workmanship or materials for a period of one (1) year from the date of shipment to Customer.

The responsibility of Diamond Products under this Warranty is limited to replacement or repair of defective parts at Diamond Products' Elyria, Ohio factory, or at a point designated by it, of such parts as shall appear to us upon inspection at such parts, to have been defective in material or workmanship, with expense for transportation and labor borne by Customer.

In no event shall Diamond Products be liable for consequential or incidental damages arising out of the failure of any Product to operate properly.

Integral units such as engines, electric motors, batteries, transmissions, etc., are excluded from this Warranty and are subject to the prime manufacturer's warranty.

THIS WARRANTY IS IN LIEU OF ALL OTHER WARRANTIES, EXPRESSED OR IMPLIED, AND ALL SUCH OTHER WARRANTIES ARE HEREBY DISCLAIMED.



333 Prospect Street, Elyria, Ohio 44035
(440) 323-4616 • (800) 321-5336 • Fax (800) 634-4035
www.diamondproducts.com